



# Hot Holding Rotisserie Companion



## Models:

**AR-7H** MANUAL CONTROL

**AR-7H** ELECTRONIC CONTROL

SHOWN WITH PASS-THROUGH OPTION

- **INSTALLATION**
- **OPERATION**
- **MAINTENANCE**



W164 N9221 Water Street • P.O. Box 450 • Menomonee Falls, Wisconsin 53052-0450 USA  
PHONE: 262.251.3800 • 800.558.8744 USA/CANADA FAX: 262.251.7067 • 800.329.8744 U.S.A. ONLY  
[www.alto-shaam.com](http://www.alto-shaam.com)



Delivery .....1  
Unpacking .....1  
Safety Procedures and Precautions .....2

**Installation**

Installation Requirements .....3  
Clearance Requirements .....3  
Leveling .....3  
Dimension Drawings .....4  
Product/Pan Capacity .....4  
Electrical Connection .....5  
Stacking Combinations & Instructions ..... 6-7  
Options & Accessories .....8

**Operating Instructions**

Start-Up Procedures .....8  
Manual Control Identification & Operation .....9  
Electronic Control Identification & Operation .....10  
General Holding Guidelines .....11  
Sanitation .....12

**Care and Cleaning**

Cleaning and Preventative Maintenance .....13  
Protecting Stainless Steel Surfaces .....13  
Cleaning Agents .....13  
Cleaning Materials .....13  
Equipment Care .....14  
Clean Daily .....14

**Service**

Troubleshooting Guide - Electronic Control .....15  
Troubleshooting Guide - Manual Control .....16  
Cable Replacement Kit .....16  
Full Assembly .....17  
Interior Service View .....18  
Door Assembly .....18  
Double Pane Curved Glass Door .....19  
Single Pane Flat Glass Door .....20  
Stainless Steel Back Panel .....21  
Electrical - Manual Control .....22  
Electrical - Electronic Control .....23

**Wire Diagrams**

Always refer to the wire diagram(s) included with the unit for most current version.

**Warranty**

Transportation Damage and Claims .....Back Cover  
Limited Warranty .....Back Cover



## DELIVERY

This Alto-Shaam appliance has been thoroughly tested and inspected to ensure only the highest quality unit is provided. Upon receipt, check for any possible shipping damage and report it at once to the delivering carrier. *See Transportation Damage and Claims section located in this manual.*

This appliance, complete with unattached items and accessories, may have been delivered in one or more packages. Check to ensure that all standard items and options have been received with each model as ordered.

Save all the information and instructions packed with the appliance. Complete and return the warranty card to the factory as soon as possible to ensure prompt service in the event of a warranty parts and labor claim.

This manual must be read and understood by all people using or installing the equipment model. Contact the Alto-Shaam Tech Team Service Department if you have any questions concerning installation, operation, or maintenance.

**NOTE:** All claims for warranty must include the full model number and serial number of the unit.

## UNPACKING

1. Carefully remove the appliance from the carton or crate.

**NOTE:** Do not discard the carton and other packaging material until you have inspected the unit for hidden damage and tested it for proper operation.

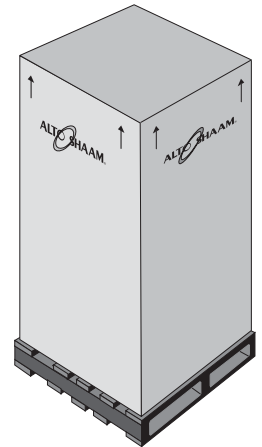

2. Read all instructions in this manual carefully before initiating the installation of this appliance.

**DO NOT DISCARD THIS MANUAL.**

This manual is considered to be part of the appliance and is to be provided to the owner or manager of the business or to the person responsible for training operators. *Additional manuals are available from the Alto-Shaam Tech Team Service Department.*

3. Remove all protective plastic film, packaging materials, and accessories from the appliance before connecting electrical power. Store any accessories in a convenient place for future use.

## SAFETY PROCEDURES AND PRECAUTIONS

Knowledge of proper procedures is essential to the safe operation of electrically and/or gas energized equipment. In accordance with generally accepted product safety labeling guidelines for potential hazards, the following signal words and symbols may be used throughout this manual.

### DANGER



Used to indicate the presence of a hazard that **WILL** cause severe personal injury, death, or substantial property damage if the warning included with this symbol is ignored.

### WARNING



Used to indicate the presence of a hazard that **CAN** cause personal injury, possible death, or major property damage if the warning included with this symbol is ignored.

### CAUTION



Used to indicate the presence of a hazard that can or will cause minor or moderate personal injury or property damage if the warning included with this symbol is ignored.

### CAUTION

Used to indicate the presence of a hazard that can or will cause minor personal injury, property damage, or a potential unsafe practice if the warning included with this symbol is ignored.

**NOTE:** Used to notify personnel of installation, operation, or maintenance information that is important but not hazard related.

1. This appliance is intended to cook, hold or process foods for the purpose of human consumption. No other use for this appliance is authorized or recommended.
2. This appliance is intended for use in commercial establishments where all operators are familiar with the purpose, limitations, and associated hazards of this appliance. Operating instructions and warnings must be read and understood by all operators and users.
3. Any troubleshooting guides, component views, and parts lists included in this manual are for general reference only and are intended for use by qualified technical personnel.
4. This manual should be considered a permanent part of this appliance. This manual and all supplied instructions, diagrams, schematics, parts lists, notices, and labels must remain with the appliance if the item is sold or moved to another location.

### NOTE

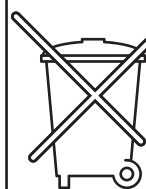

For equipment delivered for use in any location regulated by the following directive:

**DO NOT DISPOSE OF ELECTRICAL OR ELECTRONIC EQUIPMENT WITH OTHER MUNICIPAL WASTE.**

# INSTALLATION

## DANGER



**IMPROPER INSTALLATION, ALTERATION, ADJUSTMENT, SERVICE, OR MAINTENANCE COULD RESULT IN SEVERE INJURY, DEATH, OR CAUSE PROPERTY DAMAGE.**

**READ THE INSTALLATION, OPERATING AND MAINTENANCE INSTRUCTIONS THOROUGHLY BEFORE INSTALLING OR SERVICING THIS EQUIPMENT.**

## CAUTION



**TO PREVENT PERSONAL INJURY, USE CAUTION WHEN MOVING OR LEVELING THIS APPLIANCE.**

## CAUTION



**METAL PARTS OF THIS EQUIPMENT BECOME EXTREMELY HOT WHEN IN OPERATION. TO AVOID BURNS, ALWAYS USE HAND PROTECTION WHEN OPERATING THIS APPLIANCE.**



## DANGER



**DO NOT store or use gasoline or other flammable vapors or liquids in the vicinity of this or any other appliance.**

## SITE INSTALLATION

In order to maintain established National Sanitation Foundation standards, all counter-mounted models must be sealed to the counter with a R.T.V. or silastic meeting N.S.F. requirements or have legs of a sufficient 6" (152mm) height to provide minimum unobstructed space beneath the unit.

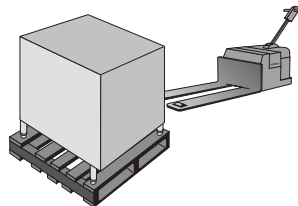
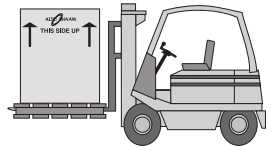

1. The appliance must be installed on a non-combustible, level surface.
2. **DO NOT** install this appliance in any area where it may be affected by any adverse conditions such as steam, grease, dripping water, high temperatures, or any other severely adverse conditions.
3. For both safety and convenience, the holding cabinet must be installed in a location to provide easy access to the controls and should be positioned at a safe and convenient height to provide easy loading and unloading of hot products.
4. This appliance must be kept free and clear of any obstructions blocking access for maintenance or service.
5. The holding cabinet can be stacked with another holding cabinet or a matching rotisserie oven. Complete stacking instructions are located in this manual.

A number of adjustments are associated with initial installation and start-up. It is important that these adjustments be conducted by a qualified service technician. Installation and start-up adjustments are the responsibility of the dealer or user. These adjustments include but are not limited to thermostat calibration, door adjustment, leveling, electrical hook-up and installation of optional casters or legs.

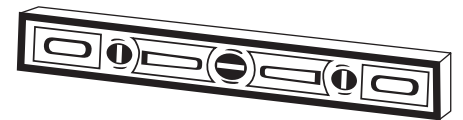

## LEVELING

Level the appliance from side-to-side and front-to-back with the use of a spirit level.

We recommend checking the level periodically to make certain the floor has not shifted nor the appliance moved.

**NOTE:** Failure to properly level this appliance can cause improper function.

## MINIMUM CLEARANCE REQUIREMENTS

A 6" (152mm) minimum clearance must be allowed at the back and both sides of the unit. Warranty will become null and void if these directions are not followed.

# INSTALLATION

## SITE INSTALLATION

**DOUBLE PANE CURVED GLASS DOOR**

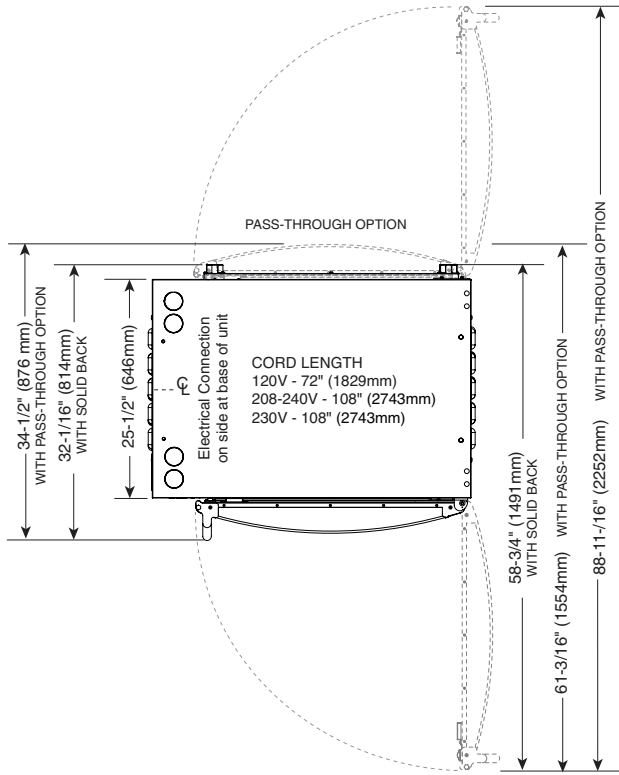

**SINGLE PANE FLAT GLASS DOOR**

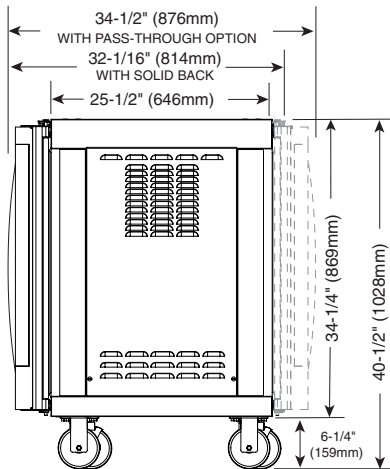
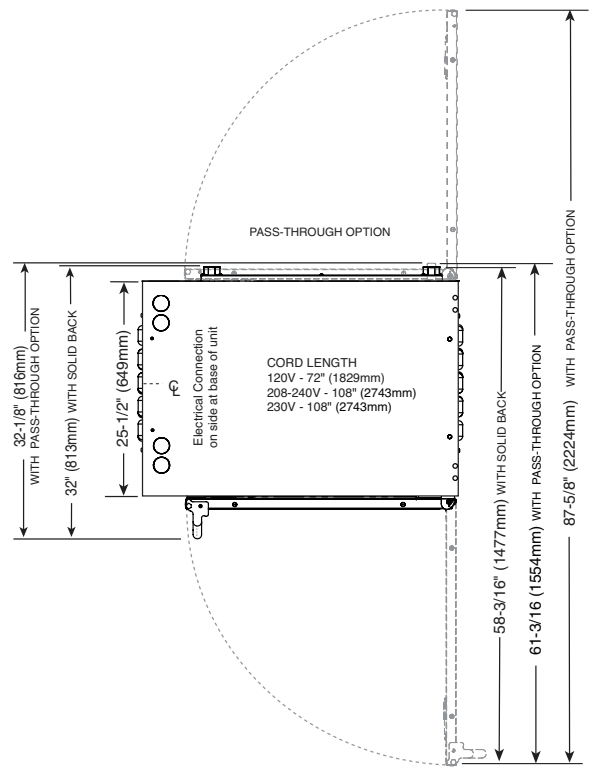

**SIDE VIEW**

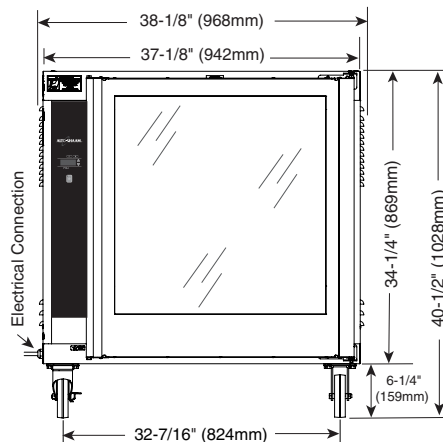

**FRONT VIEW**

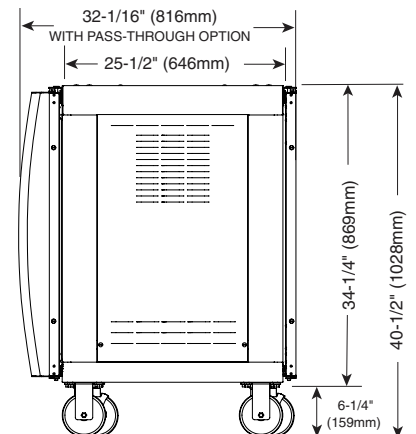

**SIDE VIEW**

PRODUCT\PAN CAPACITY	
60 lbs (27 kg) MAXIMUM	
FULL-SIZE SHEET PANS*: Eight (8) 18" x 26" x 1" (457mm x 660mm x 25mm)	HALF-SIZE SHEET PANS*: Up to Sixteen (16) 18" x 13" x 1" (457mm x 330mm x 25mm)
CHICKEN BOATS: Up to 24 (6 per shelf)	

\*WITH ADDITIONAL WIRE SHELVES

# INSTALLATION

## ELECTRICAL CONNECTION

The appliance must be installed by a qualified service technician. The oven must be properly grounded in accordance with the National Electrical Code and applicable local codes.

**DANGER**

**To avoid electrical shock, this appliance MUST be adequately grounded in accordance with local electrical codes or, in the absence of local codes, with the current edition of the National Electrical Code ANSI/NFPA No. 70. In Canada, all electrical connections are to be made in accordance with CSA C22.1, Canadian Electrical Code Part 1 or local codes.**

Plug the unit into a properly grounded receptacle ONLY, positioning the unit so that the plug is easily accessible in case of an emergency. Arcing will occur when connecting or disconnecting the unit unless all controls are in the "OFF" position.

Proper receptacle or outlet configuration or permanent wiring for this unit must be installed by a licensed electrician in accordance with applicable local electrical codes.

After wiring and power connection has been completed, turn the main power switch to the "ON" position. The main power switch can be left "ON" for daily use, but should be turned "OFF" when cleaning or performing maintenance or repairs to the rotisserie.

**DANGER**

**ELECTRICAL CONNECTIONS MUST BE MADE BY A QUALIFIED SERVICE TECHNICIAN IN ACCORDANCE WITH APPLICABLE ELECTRICAL CODES.**

**DANGER**

**ENSURE POWER SOURCE MATCHES VOLTAGE IDENTIFIED ON APPLIANCE RATING TAG.**

### REGARDING INTERNATIONAL STANDARD UNITS:

If the unit is not equipped with flexible cord with plug, an all-pole country approved disconnection device which has a contact separation of at least 3mm in all poles must be incorporated in the fixed wiring for disconnection. When using a cord without a plug, the green/yellow conductor shall be connected to the terminal which is marked with the ground symbol. If a plug is used, the socket outlet must be easily accessible. If the power cord needs replacement, use a similar one obtained from the distributor.

**For CE approved units:** To prevent an electrical shock hazard between the appliance and other appliances or metal parts in close vicinity, an equalization-bonding stud is provided. An equalization bonding lead must be connected to this stud and the other appliances / metal parts to provide sufficient protection against potential difference. The terminal is marked with the following symbol.



### Hard wired models:

Hard wired models must be equipped with a country certified external allpole disconnection switch with sufficient contact separation.

If a power cord is used for the connection of the product an oil resistant cord like H05RN or H07RN or equivalent must be used.

**NOTE:** Where local codes and CE regulatory requirements apply, appliances must be connected to an electrical circuit that is protected by an external GFCI outlet.

ELECTRICAL						
VOLTAGE	PHASE	CYCLE/HZ	AMPS	kW		
120	1	60	15.0	1.8	NEMA 5-20P 20A, 125V PLUG	
208	1	60	8.5	1.8	NEMA 6-15P	
240	1	60	9.5	2.3	15A, 250V PLUG	
230	1	50/60	9.0	2.1	CEE 7/7 PLUG RATED 250V	
					CH2-16P PLUG RATED 250V	

Wire diagrams are located in the inside access panel of the unit

# INSTALLATION

## STACKING COMBINATIONS & INSTALLATION REQUIREMENTS

### **STACKING COMBINATIONS** (FACTORY INSTALLED)

**AR-7H** companion holding cabinet *over* **AR-7H** companion holding cabinet

Requires 6" (152mm) leg assembly **5001414** or 5" (127mm) casters **4007** and stacking assembly **5009711** for applications within the United States. Applications outside the U.S. require 6" (152mm) legs with flanged feet **5001761** bolted to the floor.

[OVERALL HEIGHT: 76-7/8" (1953mm)]

**AR-7E** rotisserie *over* **AR-7H** companion holding cabinet

Requires 6" (152mm) leg assembly **5001414** or 5" (127mm) casters **4007** and stacking assembly (**5008787**, **5008948** or **5008922** - depending on voltage - see pg 8) for applications within the United States. Applications outside the U.S. requires 6" (152mm) legs with flanged feet **5001761** bolted to the floor.

[OVERALL HEIGHT: 76-7/8" (1953mm)]

**AR-7EVH** rotisserie with ventless hood *over* **AR-7H** companion holding cabinet

Requires 6" (152mm) legs with flanged feet **5001761** bolted to the floor.

[OVERALL HEIGHT: 90-13/16" (2307mm)]

### CAUTION



**STACKING APPLICATIONS  
OUTSIDE THE U.S. REQUIRE  
FLANGED FEET AND MUST BE  
BOLTED TO THE FLOOR.**

### CAUTION



**MAKE CERTAIN TO FASTEN  
EACH OF THE FOUR HOLES**

# INSTALLATION

## STACKING INSTRUCTIONS

The holding cabinet can be stacked with an identical holding cabinet or a matching rotisserie oven in either the top or bottom position.

Only screws, lock washers, and hex nut are required to fasten units together when stacking a rotisserie on top of a matching holding cabinet or a holding cabinet on top of a holding cabinet. Additional stacking hardware is required for all other combinations (SEE PREVIOUS PAGE).

All fastening holes have been prepunched. If the rotisserie oven is positioned at the bottom of a stacked configuration, make certain the oven is on a non-combustible surface. The stacking combination also requires the minimum clearance of 6" (152mm) at the back and both sides.

- 1 Remove the two side access panels of both units.
- 2 Carefully lift and place the upper unit into position aligning on bottom unit.
- 3 Secure units together by inserting a hex head screw, a flat washer, and a lock washer in each hole of the top unit and screwing them into the inserts provided on the top of the lower unit. Securely tighten all four screws.
- 4 Replace the side panels on both units.

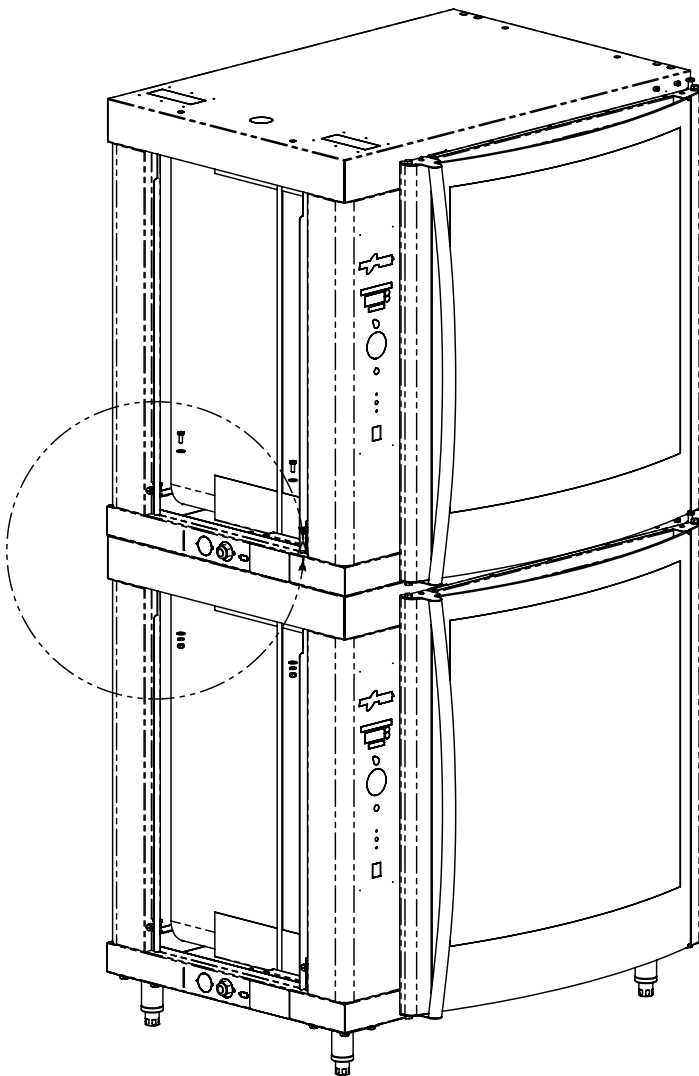

AR-7H OVER AR-7H HOLDING CABINET STACKING ASSEMBLY (5009711)

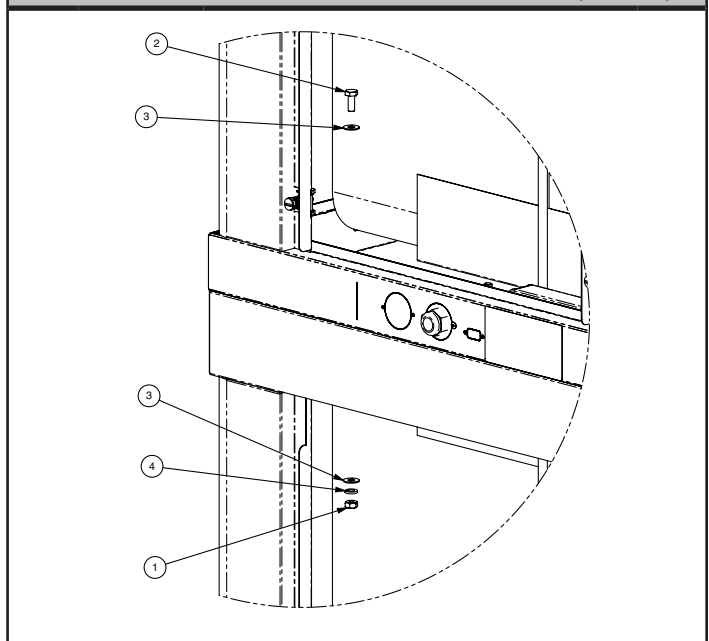

ITEM NO.	PART NO.	PART DESCRIPTION	QTY
1	NU-2437	NUT, 1/4-20 HEX S/S	4
2	SC-27385	SCREW, 1/4-20 X 3/4" LG HEX HEAD	4
3	WS-22094	WASHER, 1/4", FLAT, 5/8 OD 18-8 SS	8
4	WS-2294	WASHER 1/4" SPLIT	4



# INSTALLATION

AR-7H — OPTIONS & ACCESSORIES		
DESCRIPTION		PART NUMBER
DOOR OPTIONS	SINGLE PANE FLAT GLASS WITH HANDLE	5009591
	SINGLE PANE FLAT GLASS WITHOUT HANDLE	5009815
DOOR HANDLE	FOR SINGLE PANE GLASS DOOR ON NON-CONTROL SIDE	HD-26900
CONTROL OPTION KIT	FOR SOFTWARE DOCUMENTATION	5000886
LEGS	ASSEMBLY, 6" (152mm)	5001414
	ASSEMBLY, FLANGED FEET, 6" (152mm)	5001761
STACKING ASSEMBLY (FACTORY INSTALLED)	AR-7H OVER AR-7H	5009711
	AR-7E OVER AR-7H (208-240V, 1PH)	5008787
	AR-7E OVER AR-7H (208-240V, 3PH)	5008948
	AR-7E OVER AR-7H (380-415V)	5008922
SHELF	SHELF, CHROME PLATED WIRE	SH-2851
	SHELF, STAINLESS STEEL WIRE	SH-24720
STAND, STAINLESS STEEL	WITH STORAGE SHELF	FR-26550
	OPEN (AR-7H OVER 750-S OR 6•10EsiN)	5002058

# OPERATING INSTRUCTIONS

## START-UP

1. The unit should be installed level, and should NOT be installed in any area where it may be affected by steam, grease, dripping water, high temperatures or any other severely adverse conditions.
2. Before operating the cabinet, clean both the interior and exterior of the unit with a clean, damp cloth and mild soap solution. Rinse carefully.
3. Clean and install the cabinet side racks. Shelves should be positioned with the curved end up and toward the back of the unit.
4. Before operating the unit, become familiar with the operation of the controls. Read this manual carefully and retain it for future reference.

DANGER	
	<p>AT NO TIME SHOULD THE INTERIOR OR EXTERIOR BE STEAM CLEANED, HOSED DOWN, OR FLOODED WITH WATER OR LIQUID SOLUTION OF ANY KIND. DO NOT USE WATER JET TO CLEAN.</p>
	<p><b>SEVERE DAMAGE OR ELECTRICAL HAZARD COULD RESULT.</b></p> <p>WARRANTY BECOMES VOID IF APPLIANCE IS FLOODED</p>

# OPERATING INSTRUCTIONS

## MANUAL CONTROL IDENTIFICATION

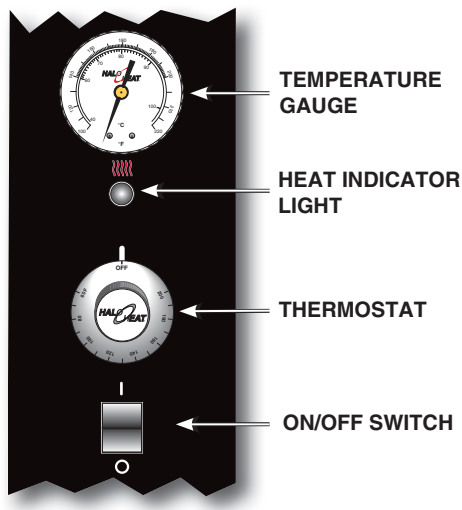

## HEATING PROCEDURE

### 1. PREHEAT AT 200°F (93°C) FOR 30 MINUTES.

When the ON/OFF Switch is turned to the ON position and the thermostat is turned clockwise, the indicator light will illuminate and will remain lit as long as the unit is calling for heat. Allow a minimum of 30 minutes of preheating before loading the holding cabinet with food. The indicator light will go OUT after approximately 30 minutes, or when the air temperature inside the unit reaches the temperature set by the operator.

### 2. LOAD THE CABINET WITH HOT FOOD ONLY.

The purpose of the holding cabinet is to maintain hot food at proper serving temperatures. Only hot food should be placed into the cabinet. Before loading the unit with food, use a food thermometer to make certain all food products are at an internal temperature range of 140° to 160°F (60° to 71°C). All food not within the proper temperature range should be heated before loading into the holding cabinet.

### 3. RESET THE THERMOSTAT TO 160°F (71°C).

Check to make certain the cabinet door is securely closed, and reset the thermostat to 160°F (71°C).

**THIS WILL NOT NECESSARILY BE THE FINAL SETTING.**

The proper temperature range for the food being held will depend on the type and quantity of product. When holding food for prolonged periods, it is advisable to periodically check the internal temperature of each item to assure maintenance of the proper temperature range.

## THERMOSTAT AND HEAT LIGHT SEQUENCE

Whenever the thermostat is turned ON the heat indicator light will indicate the power ON/OFF condition of the heating cable, and consequently, the cycling of the cabinet as it maintains the dialed cavity temperature. If the light does not illuminate after normal start-up, the main power source, thermostat, and/or light must be checked. If the warming cabinet does not hold the temperature as dialed, the calibration of the thermostat must be checked. If the warming cabinet fails to heat or heats continuously with the thermostat OFF, the thermostat must be initially checked for proper operation. If these items are checked and found to be in order, a continuity and resistance check of the heating cable should be made. SEE CIRCUIT DIAGRAM.

## THERMOSTAT CALIBRATION

The thermostat is precision calibrated at the factory. Normally, no adjustment or recalibration is necessary unless the thermostat has been mishandled in transit, changed or abused while in service. A thermostat with a sensing bulb operates on hydraulic pressure, consequently, any bending of the bulb results in a change in its volume, and alters the accuracy of the thermostat calibration.

A thermostat should be checked or recalibrated by placing a quality, thermal indicator at the center of an empty holding cavity. **DO NOT CALIBRATE WITH ANY FOOD PRODUCT IN THE CABINET.** The thermostat should be set at 160°F (71°C), and should be allowed to stabilize at that setting for a minimum of one hour. Following temperature stabilization, the center of the thermal swing of the air temperature within the cabinet should approximately coincide with the thermostat dial setting.

If calibration is necessary, the calibration screw should be adjusted with great care. The calibration screw of the thermostat is located in the thermostat dial shaft. With the shaft held stationary, a minute, clockwise motion of the calibration screw appreciably lowers the thermostat setting. A reverse, or counter-clockwise motion appreciably raises the thermostat setting. After achieving the desired cycling of the thermostat, the calibration screw must be sealed. Place a few drops of enamel sealant directly on the calibration screw.

**(RED NAIL POLISH OR EQUIVALENT IS ACCEPTABLE.)**

# OPERATING INSTRUCTIONS

## ELECTRONIC CONTROL IDENTIFICATION

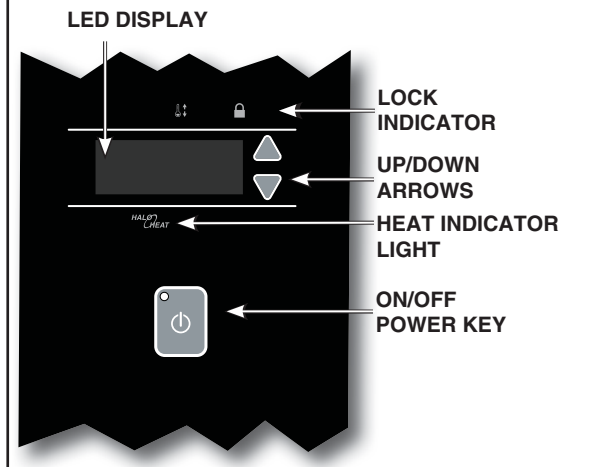

## HEATING PROCEDURE

- 1. PREHEAT AT 200°F (93°C) FOR 30 MINUTES.**

Press the ON key, and set the temperature to 200°F (93°C) by using the UP/DOWN arrow keys. Allow a minimum of 30 minutes preheating time before loading the holding cabinet with food. The LED heat indicator light will illuminate while the heating wraps are energized.
- 2. LOAD WITH HOT FOOD ONLY.**

The purpose of the holding cabinet is to maintain hot food at proper serving temperature. Only **hot** food should be placed into the cabinet. Before loading the cabinet with food, use a food thermometer to make certain all products are at an internal temperature range of 140° to 160°F (60° to 71°C). Any food product not within the proper temperature range should be heated before loading into the holding cabinet.
- 3. RESET THE CONTROL TO 160°F (71°C).**

Check to make certain the cabinet door is securely closed, and reset to 160°F (71°C) by using the UP/DOWN key. **THIS WILL NOT NECESSARILY BE THE FINAL SETTING.** The proper temperature range will depend on the type and quantity of product. When holding food for prolonged periods, it is advisable to periodically check the internal temperature of each item with a food thermometer to assure maintenance of the proper temperature range of 140° to 160°F (60° to 71°C).

## ON/OFF KEY

Press the on/off key once and the power indicator light will illuminate. Press and hold the on/off key until the LED display turns off (at least three seconds) and power indicator light goes out.

## UP DOWN ARROW KEY

The up and down arrow keys are used for a variety of settings when selecting the holding temperature. If an arrow key is pressed and released the display will show the current set temperature for two seconds. If an arrow key is held (at least eight seconds), the value will change at a rapid rate. If the arrow key is pressed and released in rapid succession, the set temperature will change by increments of one degree.

## CALIBRATION INSTRUCTIONS

Turn the unit on with a quality monitoring thermocouple in the center of the cavity, and allow the unit to reach and stabilize at a hold temperature of 160°F (70°C). After the unit is stable, check the monitoring thermocouple against the set temperature, and adjust the offset by pressing the up and down arrows at the same time (for 8 seconds) until a temperature offset value is displayed. Change the value by pressing either the up button to increase the offset in a positive direction or the down button to decrease the offset temperature in a negative direction. For example, if the monitored temperature is 155°F (68°C) and the set temperature is 160° (70°C), the offset should be adjusted by -5 to bring the monitored temperature to 160° (70°C).

## ENABLE/DISABLE BEEPER

A beeper sounds when an error code is displayed. To choose between beeper on and beeper off mode, the control must be off, then press and hold the down arrow key until the current beeper state ("ON" or "OFF") is displayed on the screen. Toggle between the states by pressing either the UP or DOWN arrow.

## FAHRENHEIT/CELSIUS

With the control off, to choose between Fahrenheit and Celsius, press and hold the up arrow key until the current scale is displayed on the screen. Press either UP or DOWN arrow to toggle between the two options.

The control has a four-digit LED display. When the display is on, it will show current holding temperature, as well as diagnostic information.

## CONTROL LOCK

The warmer controls can be locked so that no changes can be made to the set temperature.

To lock the display, press and hold the ON/OFF key and the Up Arrow key at the same time. The lock LED will illuminate. When the lock LED is illuminated, additional programming will not be functional other than the key sequence required to unlock the panel.

To unlock the display, press and hold the ON/OFF key and the Down Arrow key at the same time. The lock LED will extinguish. The panel keys will resume normal function.

# OPERATING INSTRUCTIONS

## GENERAL HOLDING GUIDELINES

Chefs, cooks and other specialized food service personnel employ varied methods of cooking. Proper holding temperatures for a specific food product must be based on the moisture content of the product, product density, volume, and proper serving temperatures. Safe holding temperatures must also be correlated with palatability in determining the length of holding time for a specific product.

Halo Heat maintains the maximum amount of product moisture content without the addition of water, water vapor, or steam. Maintaining maximum natural product moisture preserves the natural flavor of the product and provides a more genuine taste. In addition to product moisture retention, the gentle properties of Halo Heat maintain a consistent temperature throughout the cabinet without the necessity of a heat distribution fan, thereby preventing further moisture loss due to evaporation or dehydration.

In an enclosed holding environment, too much moisture content is a condition which can be relieved. A product achieving extremely high temperatures in preparation must be allowed to decrease in temperature before being placed in a controlled holding atmosphere. If the product is not allowed to decrease in temperature, excessive condensation will form increasing the moisture content on the outside of the product. To preserve the safety and quality of freshly cooked foods however, a maximum of 1 to 2 minutes must be the only time period allowed for the initial heat to be released from the product.

Most Halo Heat holding equipment is provided with a thermostat control between 60° and 200°F (16° to 93°C). If the unit is equipped with vents, close the vents for moist holding and open the vents for crisp holding.

If the unit is equipped with a thermostat indicating a range of between 1 and 10, use a metal-stemmed indicating thermometer to measure the internal temperature of the product(s) being held. Adjust the thermostat setting to achieve the best overall setting based on internal product temperature.

HOLDING TEMPERATURE RANGE		
MEAT	FAHRENHEIT	CELSIUS
BEEF ROAST — Rare	130°F	54°C
BEEF ROAST — Med/Well Done	155°F	68°C
BEEF BRISKET	160° — 175°F	71° — 79°C
CORN BEEF	160° — 175°F	71° — 79°C
PASTRAMI	160° — 175°F	71° — 79°C
PRIME RIB — Rare	130°F	54°C
STEAKS — Broiled/Fried	140° — 160°F	60° — 71°C
RIBS — Beef or Pork	160°F	71°C
VEAL	160° — 175°F	71° — 79°C
HAM	160° — 175°F	71° — 79°C
PORK	160° — 175°F	71° — 79°C
LAMB	160° — 175°F	71° — 79°C
POULTRY		
CHICKEN — Fried/Baked	160° — 175°F	71° — 79°C
DUCK	160° — 175°F	71° — 79°C
TURKEY	160° — 175°F	71° — 79°C
GENERAL	160° — 175°F	71° — 79°C
FISH/SEAFOOD		
FISH — Baked/Fried	160° — 175°F	71° — 79°C
LOBSTER	160° — 175°F	71° — 79°C
SHRIMP — Fried	160° — 175°F	71° — 79°C
BAKED GOODS		
BREADS/ROLLS	120° — 140°F	49° — 60°C
MISCELLANEOUS		
CASSEROLES	160° — 175°F	71° — 79°C
DOUGH — Proofing	80° — 100°F	27° — 38°C
EGGS — Fried	150° — 160°F	66° — 71°C
FROZEN ENTREES	160° — 175°F	71° — 79°C
HORS D'OEUVRES	160° — 180°F	71° — 82°C
PASTA	160° — 180°F	71° — 82°C
PIZZA	160° — 180°F	71° — 82°C
POTATOES	180°F	82°C
PLATED MEALS	140° — 165°F	60° — 74°C
SAUCES	140° — 200°F	60° — 93°C
SOUP	140° — 200°F	60° — 93°C
VEGETABLES	160° — 175°F	71° — 79°C
<b>THE HOLDING TEMPERATURES LISTED ARE SUGGESTED GUIDELINES ONLY. ALL FOOD HOLDING SHOULD BE BASED ON INTERNAL PRODUCT TEMPERATURES. ALWAYS FOLLOW LOCAL HEALTH (HYGIENE) REGULATIONS FOR ALL INTERNAL TEMPERATURE REQUIREMENTS.</b>		

# SANITATION

Food flavor and aroma are usually so closely related that it is difficult, if not impossible, to separate them. There is also an important, inseparable relationship between cleanliness and food flavor. Cleanliness, top operating efficiency, and appearance of equipment contribute considerably to savory, appetizing foods. Good equipment that is kept clean, works better and lasts longer.

Most food imparts its own particular aroma and many foods also absorb existing odors. Unfortunately, during this absorption there is not distinction between GOOD and BAD odors. The majority of objectionable flavors and odors troubling food service operations are caused by bacteria growth. Sourness, rancidity, mustiness, stale or other OFF flavors are usually the result of germ activity.

The easiest way to insure full, natural food flavor is through comprehensive cleanliness. This means good control of both visible soil (dirt) and invisible soil (germs). A thorough approach to sanitation will provide essential cleanliness. It will assure an attractive appearance of equipment, along with maximum efficiency and utility. More importantly, a good sanitation program provides one of the key elements in the prevention of food-borne illnesses.

A controlled holding environment for prepared foods is just one of the important factors involved in the prevention of food-borne illnesses. Temperature monitoring and control during receiving, storage, preparation, and the service of foods are of equal importance.

The most accurate method of measuring safe temperatures of both hot and cold foods is by internal product temperature. A quality thermometer is an effective tool for this purpose, and should be routinely used on all products that require holding at a specific temperature.

A comprehensive sanitation program should focus on the training of staff in basic sanitation procedures. This includes personal hygiene, proper handling of raw foods, cooking to a safe internal product temperature, and the routine monitoring of internal temperatures from receiving through service.

Most food-borne illnesses can be prevented through proper temperature control and a comprehensive program of sanitation. Both these factors are important to build quality service as the foundation of customer satisfaction. Safe food handling practices to prevent food-borne illness is of critical importance to the health and safety of your customers.

HACCP, an acronym for Hazard Analysis (at) Critical Control Points, is a quality control program of operating procedures to assure food integrity, quality, and safety. Taking steps necessary to augment food safety practices is both cost effective and relatively simple. While HACCP guidelines go far beyond the scope of this manual, additional information is available by contacting:

**CENTER FOR FOOD SAFETY AND APPLIED  
NUTRITION FOOD AND DRUG ADMINISTRATION  
1-888-SAFEFOOD**

INTERNAL FOOD PRODUCT TEMPERATURES		
<b>HOT FOODS</b>		
DANGER ZONE	40° TO 140°F	(4° TO 60°C)
CRITICAL ZONE	70° TO 120°F	(21° TO 49°C)
SAFE ZONE	140° TO 165°F	(60° TO 74°C)
<b>COLD FOODS</b>		
DANGER ZONE	ABOVE 40°F	(ABOVE 4°C)
SAFE ZONE	36° TO 40°F	(2° TO 4°C)
<b>FROZEN FOODS</b>		
DANGER ZONE	ABOVE 32°F	(ABOVE 0°C)
CRITICAL ZONE	0° TO 32°F	(-18° TO 0°C)
SAFE ZONE	0°F or below	(-18°C or below)

# CARE AND CLEANING

## CLEANING AND PREVENTATIVE MAINTENANCE

### PROTECTING STAINLESS STEEL SURFACES



It is important to guard against corrosion in the care of stainless steel surfaces. Harsh, corrosive, or inappropriate chemicals can completely destroy the protective surface layer of stainless steel. Abrasive

pads, steel wool, or metal implements will abrade surfaces causing damage to this protective coating and will eventually result in areas of corrosion. Even water, particularly hard water that contains high to moderate concentrations of chloride, will cause oxidation and pitting that result in rust and corrosion. In addition, many acidic foods spilled and left to remain on metal surfaces are contributing factors that will corrode surfaces.



Proper cleaning agents, materials, and methods are vital to maintaining the appearance and life of this appliance. Spilled foods should be removed and the area wiped as soon as possible but at the very least, a minimum of once a day. Always thoroughly rinse surfaces after using a cleaning agent and wipe standing water as quickly as possible after rinsing.

### CLEANING AGENTS

Use non-abrasive cleaning products designed for use on stainless steel surfaces. Cleaning agents must be chloride-free compounds and must not contain quaternary salts. Never use hydrochloric acid (muriatic acid) on stainless steel surfaces. Always use the proper cleaning agent at the manufacturer's recommended strength. Contact your local cleaning supplier for product recommendations.

### CLEANING MATERIALS

The cleaning function can usually be accomplished with the proper cleaning agent and a soft, clean cloth. When more aggressive methods must be employed, use a non-abrasive scouring pad on difficult areas and make certain to scrub with the visible grain of surface metal to avoid surface scratches. Never use wire brushes, metal scouring pads, or scrapers to remove food residue.

 <b>CAUTION</b>	
 NO SCRAPERS	<b>TO PROTECT STAINLESS STEEL SURFACES, COMPLETELY AVOID THE USE OF ABRASIVE CLEANING COMPOUNDS, CHLORIDE BASED CLEANERS, OR CLEANERS CONTAINING QUATERNARY SALTS. NEVER USE HYDROCHLORIC ACID (MURIATIC ACID) ON STAINLESS STEEL. NEVER USE WIRE BRUSHES, METAL SCOURING PADS OR SCRAPERS.</b>
 NO WIRE BRUSHES	
 NO STEEL PADS	

# CARE AND CLEANING

## EQUIPMENT CARE

Under normal circumstances, this cabinet should provide you with long and trouble free service. There is no preventative maintenance required, however, the following Equipment Care Guide will maximize the potential life and trouble free operation of this oven. The cleanliness and appearance of this equipment will contribute considerably to operating efficiency and savory, appetizing food. Good equipment that is kept clean works better and lasts longer.



<b>DANGER</b>	
	<b>DISCONNECT UNIT FROM POWER SOURCE BEFORE CLEANING OR SERVICING.</b>

<b>CAUTION</b>	
	<b>METAL PARTS OF THIS EQUIPMENT BECOME EXTREMELY HOT WHEN IN OPERATION. TO AVOID BURNS, ALWAYS USE HAND PROTECTION WHEN OPERATING THIS APPLIANCE.</b>

## CLEAN DAILY

1. Press the electrical power switch to the "off" position.
2. Allow holding cabinet surfaces to cool.
3. Disconnect the cabinet from the electrical power source.
4. Remove all detachable items such as wire shelves and side racks. Wash all detached items separately in a ware washing area or sink. Do not use abrasive or corrosive cleaners.
5. Wipe the interior metal surfaces of the cabinet with a paper towel to remove loose food debris.
6. Clean interior with a damp cloth or sponge and any good commercial detergent at the recommended strength.
7. Spray heavily soiled areas with a water soluble degreaser and let stand for 10 minutes. After 10 minutes, remove soil with a plastic scouring pad.

**NOTE:** Avoid the use of abrasive cleaning compounds, chloride based cleaners, or cleaners containing quaternary salts. To protect metal finish on stainless steel, never use hydrochloric acid (muriatic acid) on stainless steel.

8. Remove excess water with sponge and wipe dry with a clean cloth or air dry. Leave door open until interior is completely dry. Always replace all removable parts including drip pan and grease deflection trays before operating.
9. Interior can be wiped with a sanitizing solution after cleaning and rinsing. This solution must be approved for use on stainless steel food contact surfaces.
10. Wipe control panel and door handle(s) thoroughly since these areas harbor food debris and bacteria. Dry the control panel with a clean, soft cloth.
11. To help maintain the protective film coating on polished stainless steel, clean the exterior of the cabinet with a cleaner recommended for stainless steel surfaces. Spray the cleaning agent on a clean cloth and wipe with the grain of the stainless steel. For optional color coated exterior surfaces, wipe with a damp cloth or sponge and wipe dry with a clean cloth.
12. Clean glass doors with a standard, commercial glass cleaner.

<b>CAUTION</b>	
	<b>Always follow appropriate state or local health (hygiene) regulations regarding all applicable cleaning and sanitation requirements for equipment.</b>

<b>DANGER</b>	
	<b>AT NO TIME SHOULD THE INTERIOR OR EXTERIOR BE STEAM CLEANED, HOSED DOWN, OR FLOODED WITH WATER OR LIQUID SOLUTION OF ANY KIND. DO NOT USE WATER JET TO CLEAN.</b>
	<b>SEVERE DAMAGE OR ELECTRICAL HAZARD COULD RESULT.</b>
	<b>WARRANTY BECOMES VOID IF APPLIANCE IS FLOODED</b>

## TROUBLESHOOTING GUIDE - ELECTRONIC CONTROL

Code	Description	Possible Cause
E-10	<b>Cavity air sensor shorted</b>	Cavity air sensor reading < 5°F. Verify sensor integrity. See sensor test instructions below.
E-11	<b>Cavity air sensor open</b>	Cavity air sensor reading > 517°F. Verify sensor integrity. See sensor test instructions below.
E-20	<b>Product probe is shorted</b> <i>Oven will cook in time only</i>	Product probe reading < 5°F. Verify sensor integrity. See sensor test instructions below.
E-21	<b>Product probe is open</b> <i>Oven will cook in time only</i>	Product Probe reading > 517°F. Verify sensor integrity. See sensor test instructions below.
E-30	<b>Under temperature</b>	Unit has not reached (set-point - 25°F) for more than 90 minutes.
E-31	<b>Over temperature</b>	Unit has been higher than 25°F above the maximum cavity set-point for more than 2 minutes. <b>Note:</b> Holding Cabinets with this error code are more than 145°F higher than the maximum set-point.
E-32	<b>Safety switch open (Aux hi-limit switch)</b>	Contact factory.
E-38	<b>Internal software error</b>	Contact factory.
E-39	<b>Sensor error</b>	Contact factory.
E-50	<b>Temp. measurement error</b>	Contact factory.
E-51	<b>Temp. measurement error</b>	Contact factory.
E-60	<b>Real time clock error</b>	Data set to factory default. Ensure that date and time are correct if applicable.
E-61	<b>Real time clock error</b>	Contact factory.
E-64	<b>Clock is not oscillating</b>	Contact factory.
E-70	<b>Configuration connector error (DIP switch)</b>	Refer to wiring diagram for the particular model and ensure dip switches on the control match the settings called out on the WD. If the dip switch settings are correct according to the print replace the control.
E-78	<b>Voltage low</b>	Voltage below 90 VAC on a 125 VAC unit, or below 190 VAC on a 208-240 VAC unit. Correct voltage.
E-79	<b>Voltage high</b>	Voltage over 135 VAC on a 125 VAC unit, or over 250 VAC on a 208-240 VAC unit. Correct voltage.
E-80	<b>EEPROM Error</b>	Ensure that all temperatures and times are properly set. Contact factory if problem persists.
E-81	<b>EEPROM Error</b>	Contact factory.
E-82	<b>EEPROM Error</b>	Contact factory.
E-83	<b>EEPROM Error</b>	Contact factory.
E-85	<b>EEPROM Error</b>	All timers, if previously on, are now off. Possible bad EEPROM.
E-86	<b>EEPROM Error</b>	Stored HACCP memory corrupted. HACCP Address reset to 1. Possible bad EEPROM. Contact factory if problem persists.
E-87	<b>EEPROM Error</b>	Stored offsets corrupted. Offsets reset to 0. Control may need a recalibration. Possible bad EEPROM. Contact factory if problem persists.
E-88	<b>EEPROM Error</b>	All timer set-points are reset to 1 minute. Timers, if previously on, are now off. Possible bad EEPROM.
E-90	<b>Button stuck</b>	A button has been held down for >60 seconds. Adjust control. Error will reset when the problem has been resolved.
E-91	<b>Input failure</b>	Contact factory.
E-dS	<b>Datakey error</b>	Datakey digital signature incompatible. Cycle power, and install compatible Datakey if error persists.
E-dT	<b>Datakey error</b>	Datakey incompatible with control. Install compatible Datakey.
E-dU	<b>Datakey unplugged</b>	Install Datakey and cycle power to control to clear error.
dLto	<b>Datalogger has timed out</b>	Cycle power. Contact factory if error persists.
dLSD	<b>Micro SD card not plugged in</b>	Plug in SD card and cycle power. Contact factory if error persists.

*Note: If in doubt, always cycle the power to the control and contact factory if the problem persists.*

### To test probe and air sensor:

Test probe and air sensor by placing sensor in ice water bath and using an ohmmeter set on the ohm scale. The reading should be 100 ohms resistance. If it is more than 2 ohms higher or lower, sensor needs to be replaced.

# SERVICE

## TROUBLESHOOTING GUIDE - MANUAL CONTROL

TROUBLE	POSSIBLE CAUSE	REMEDY
Unit does not operate.	Insufficient power supply Defective power cord or plug Defective power switch. Defective thermostat.	Check power source. Check and replace if necessary. Check and replace if necessary. Replace thermostat and calibrate.
Cannot control temperature.	Defective thermostat. Grounded element.	Replace thermostat and calibrate. Replace element (check element to ground Ohm element @ 27.7 Ohms).
Temperature gauge readout incorrect.	Defective temperature gauge Calibration off.	Replace temperature gauge. Calibrate according to instructions found on page 9.

**DANGER**

**LOCK-OUT OR POST BREAKER PANEL UNTIL SERVICE WORK HAS BEEN COMPLETED.**

**DANGER**

**DISCONNECT UNIT FROM POWER SOURCE BEFORE CLEANING OR SERVICING.**

### CAUTION

**THIS SECTION IS PROVIDED FOR THE ASSISTANCE OF QUALIFIED SERVICE TECHNICIANS ONLY AND IS NOT INTENDED FOR USE BY UNTRAINED OR UNAUTHORIZED SERVICE PERSONNEL.**

**DANGER**

**ELECTRICAL CONNECTIONS MUST BE MADE BY A QUALIFIED SERVICE TECHNICIAN IN ACCORDANCE WITH APPLICABLE ELECTRICAL CODES.**

CABLE REPLACEMENT KIT	
CABLE HEATING SERVICE KIT NO. 4876	
INCLUDES:	
CB-3044	CABLE HEATING ELEMENT.....210 FEET
CR-3226	RING CONNECTOR ..... 8
IN-3488	INSULATION CORNER .....8 FEET
BU-3105	SHOULDER BUSHING ..... 8
BU-3106	CUP BUSHING ..... 8
SL-3063	INSULATING SLEEVE ..... 8
TA-3540	HIGH TEMPERATURE TAPE .....1 ROLL
ST-2439	STUD, 10/32 ..... 8
NU-2215	HEX NUT..... 16

## FULL ASSEMBLY SERVICE VIEW (CURVED DOOR SHOWN)

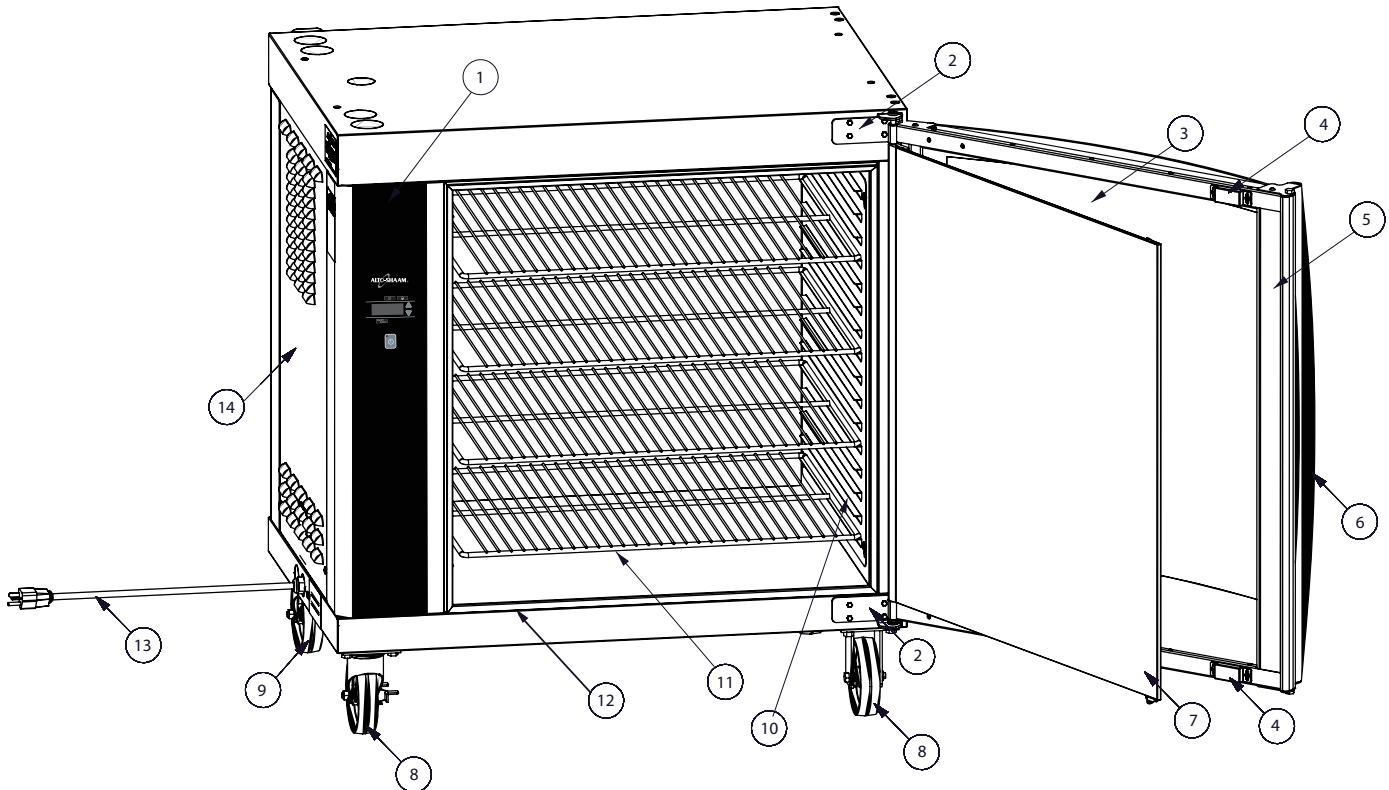

* NOT SHOWN		MODEL >	MANUAL		ELECTRONIC	
ITEM	DESCRIPTION		PART NO.	QTY	PART NO.	QTY
1	CONTROL PANEL OVERLAY		PE-26003*	1	PE-25746	1
2	HINGES, CURVED DOOR	TOP	1007672	2	1007672	2
		BOTTOM	1007673	2	1007673	2
	HINGES, FLAT DOOR	TOP	1002596*	2	1002596*	2
		BOTTOM	1002597*	2	1002597*	2
3	OUTER GLASS ONLY, CURVED		5007824	1	5007824	1
4	DOOR MAGNETS		MA-27568	2	MA-27568	2
5	DOOR ASSEMBLY COMPLETE, CURVED GLASS	CONTROL SIDE	5005773	1	5005773	1
		NON-CONTROL SIDE	5006426*	1	5006426*	1
6	HANDLE		HD-26900	1	HD-26900	1
7	INNER GLASS	CONTROL SIDE	5006779	1	5006779	1
		NON-CONTROL SIDE	5008322	1	5008322	1
8	CASTERS	SWIVEL	CS-2026	2	CS-2026	2
		RIGID	CS-2025	2	CS-2025	2
10	SIDE RACKS	LEFT-HAND	5004361	1	5004361	1
		RIGHT-HAND	5001901	1	5001901	1
11	SHELF, STAINLESS STEEL		SH-24720	4	SH-24720	4
12	GASKET, DOOR		GS-25753	2	GS-25753	2
13	CORDSET	120V, 72" (1829mm)	CD-3397	1	CD-3397	1
		208/240V, 108" (2743mm)	CD-33840	1	CD-33840	1
		230V, 108" (2743mm)	CD-3922	1	CD-3922	1
		230V, 108" (2743mm)	CD-36231	1	CD-36231	1
14	PANEL, CONTROL SIDE ACCESS		CONTACT FACTORY WITH SERIAL #			

Part numbers and drawings are subject to change without notice.

# SERVICE

## INTERIOR SERVICE VIEW

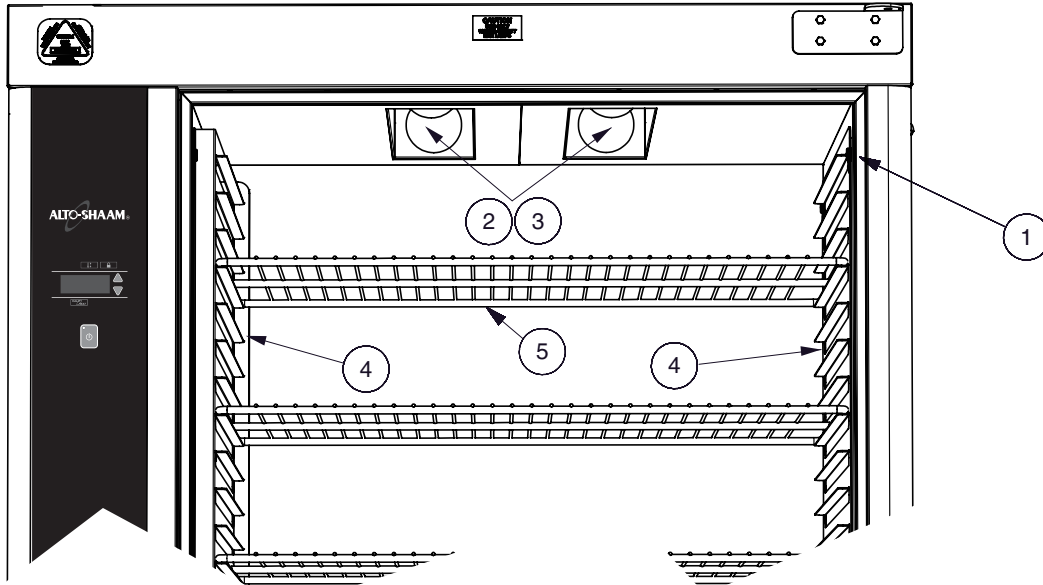

ITEM	DESCRIPTION	MODEL >	MANUAL		ELECTRONIC	
			PART NO.	QTY	PART NO.	QTY
1	GASKET, DOOR		GS-25753	2	GS-25753	2
2	LAMP	120V	LP-33598	4	LP-33598	4
		208/240V & 230V	LP-33803	4	LP-33803	4
3	LAMP RECEPTACLE		RP-3952	4	RP-3952	4
4	SIDE RACKS	LEFT-HAND	5001901	1	5001901	1
		RIGHT-HAND	5004361	1	5004361	1
5	SHELF		SH-24720	4	SH-24720	4

## DOOR ASSEMBLY (CURVED DOOR, CONTROL SIDE SHOWN)

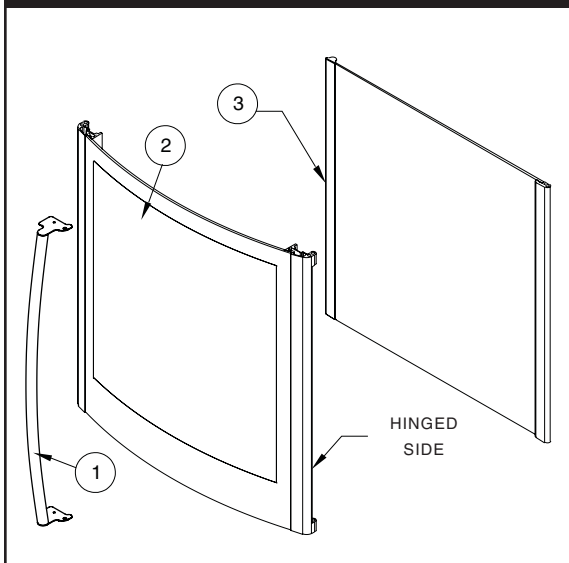

ITEM	DESCRIPTION	PART NO.	QTY	
1	HANDLE, DOOR	HD-26900	1	
2	DOOR, OUTER GLASS	5007824	1	
3	DOOR, INNER GLASS	CONTROL SIDE	5006779	1
		NON-CONTROL SIDE	5008322	1

### FASTENERS REQUIRED

DESCRIPTION	PART NO.	QTY
WASHER, DOOR SPACE, BOTTOM	1002143	1
WASHER, FLAT, M8	WS-22298	1
SCREW, 5/16-18 X 5/8	SC-2900	3
PIN, DOOR, TOP	PI-26350	1
PIN, DOOR, BOTTOM	PI-26352	1
NUT, HEX JAM 5/16-18	NU-25897	1
SCREW, INSERT	SC-25781	1
SCREW, 8-32 X 3/8	SC-22378	6

Part numbers and drawings are subject to change without notice.

## DOUBLE PANE CURVED GLASS DOOR

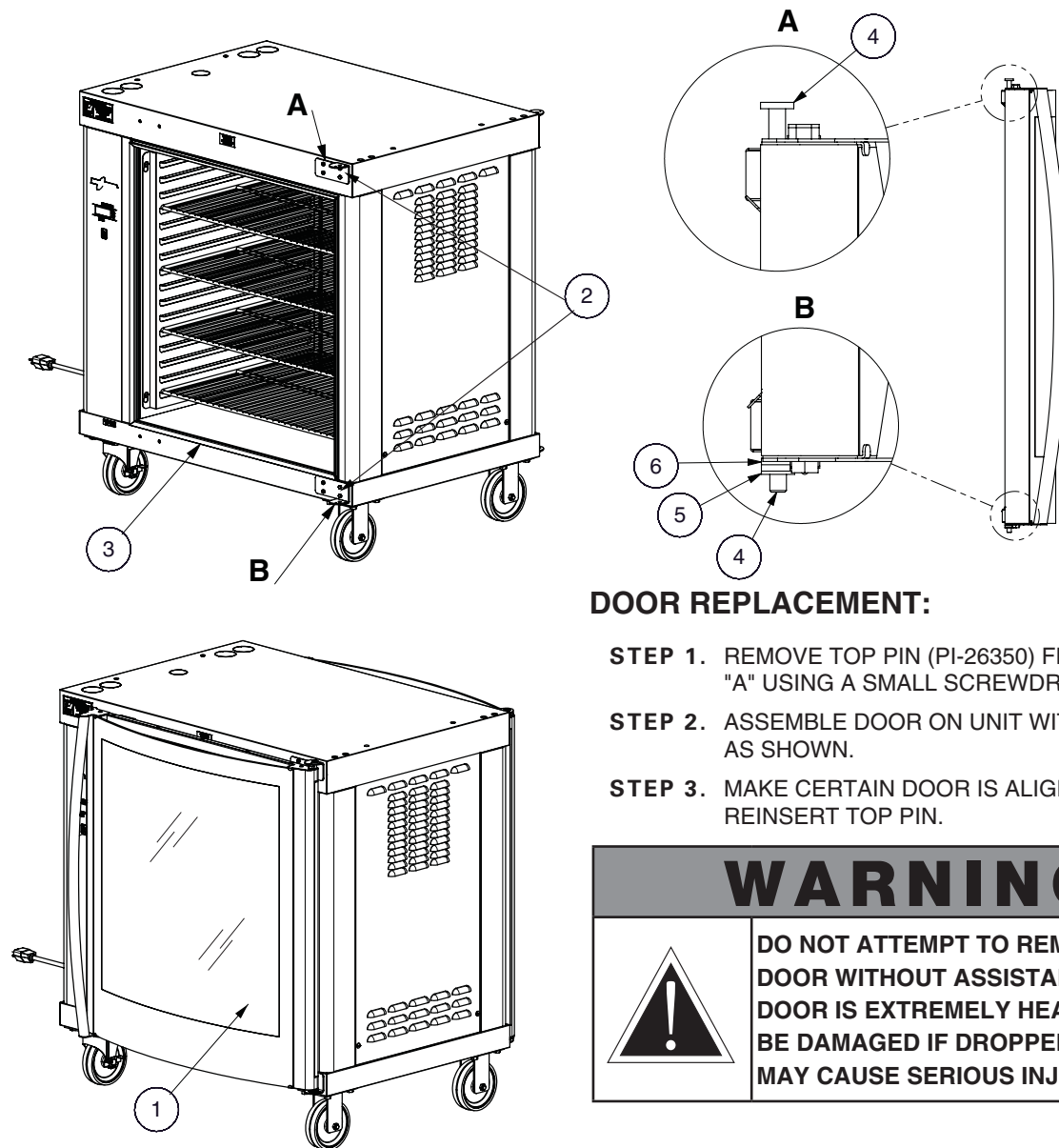

### DOOR REPLACEMENT:

- STEP 1.** REMOVE TOP PIN (PI-26350) FROM BRACKET "A" USING A SMALL SCREWDRIVER.
- STEP 2.** ASSEMBLE DOOR ON UNIT WITH SPACERS AS SHOWN.
- STEP 3.** MAKE CERTAIN DOOR IS ALIGNED AND REINSERT TOP PIN.

## WARNING



**DO NOT ATTEMPT TO REMOVE THE DOOR WITHOUT ASSISTANCE. THE DOOR IS EXTREMELY HEAVY, WILL BE DAMAGED IF DROPPED, AND MAY CAUSE SERIOUS INJURY.**

*NOT SHOWN		MODEL >	MANUAL		ELECTRONIC	
ITEM	DESCRIPTION		PART NO.	QTY	PART NO.	QTY
1	DOOR ASSEMBLY, CURVED	CONTROL SIDE	5005773	1	5005773	1
		NON-CONTROL SIDE*	5006426	1	5006426	1
2	HINGES, DOOR	TOP	1007672	1	1007672	1
		BOTTOM	1007673	1	1007673	1
3	GASKET, DOOR		GS-25753	2	GS-25753	2
4	PIN, DOWEL	TOP	PI-26350	2	PI-26350	2
		BOTTOM	PI-26352	2	PI-26352	2
5	WASHER		WS-22298	1	WS-22298	1
6	SPACER		1002143	1	1002143	1

Part numbers and drawings are subject to change without notice.

# SERVICE

## SINGLE PANE FLAT GLASS DOOR

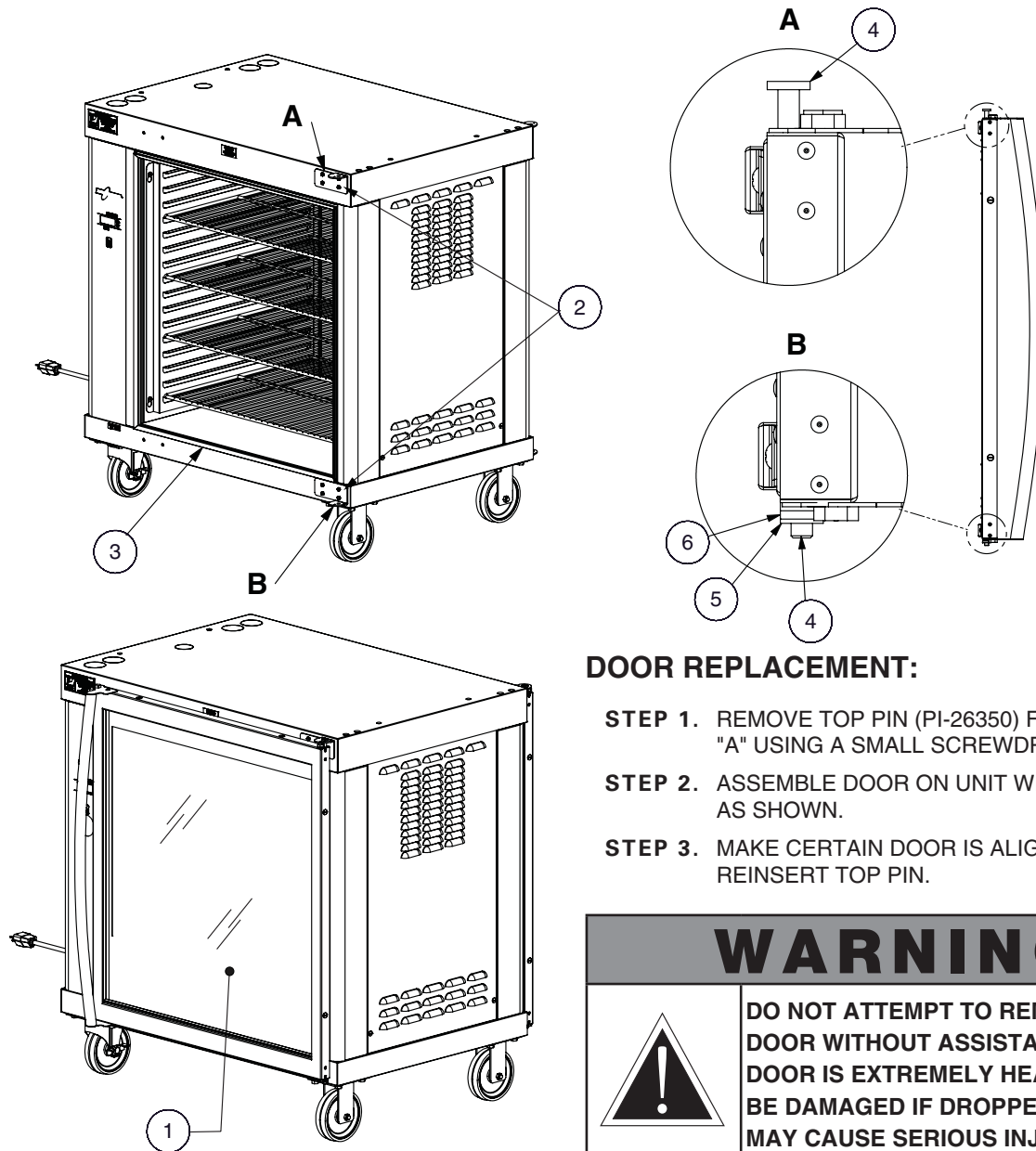

### DOOR REPLACEMENT:

- STEP 1.** REMOVE TOP PIN (PI-26350) FROM BRACKET "A" USING A SMALL SCREWDRIVER.
- STEP 2.** ASSEMBLE DOOR ON UNIT WITH SPACERS AS SHOWN.
- STEP 3.** MAKE CERTAIN DOOR IS ALIGNED AND REINSERT TOP PIN.

## WARNING



**DO NOT ATTEMPT TO REMOVE THE DOOR WITHOUT ASSISTANCE. THE DOOR IS EXTREMELY HEAVY, WILL BE DAMAGED IF DROPPED, AND MAY CAUSE SERIOUS INJURY.**

*NOT SHOWN		MODEL >	MANUAL		ELECTRONIC	
ITEM	DESCRIPTION		PART NO.	QTY	PART NO.	QTY
1	DOOR ASSEMBLY, FLAT	CONTROL SIDE	5009591	1	5009591	1
		NON-CONTROL SIDE*	5009815	1	5009815	1
2	HINGES, DOOR	TOP	1002596	1	1002596	1
		BOTTOM	1002597	1	1002597	1
3	GASKET, DOOR		GS-25753	2	GS-25753	2
4	PIN, DOWEL	TOP	PI-26350	2	PI-26350	2
		BOTTOM	PI-26352	2	PI-26352	2
5	WASHER		WS-22298	1	WS-22298	1
6	SPACER		1002143	1	1002143	1

Part numbers and drawings are subject to change without notice.

## STAINLESS STEEL BACK PANEL

### BACK REPLACEMENT:

- STEP 1:** REMOVE REAR DOOR, RUBBER GASKET, HINGES, AND 28 SCREWS FROM GASKET CHANNEL
- STEP 2:** ATTACH INNER BACK PANEL WITH 24: SC-25849
- STEP 3:** INSERT IN-2003 INTO OUTER BACK PANEL
- STEP 4:** ATTACH OUTER BACK PANEL WITH 4: SC-27843
- STEP 5:** ATTACH 4 SPACER BRACKETS WITH 2 EACH: SC-2459
- STEP 6:** ATTACH 2 HINGE COVER PLATES WITH 4 EACH: SC-23151

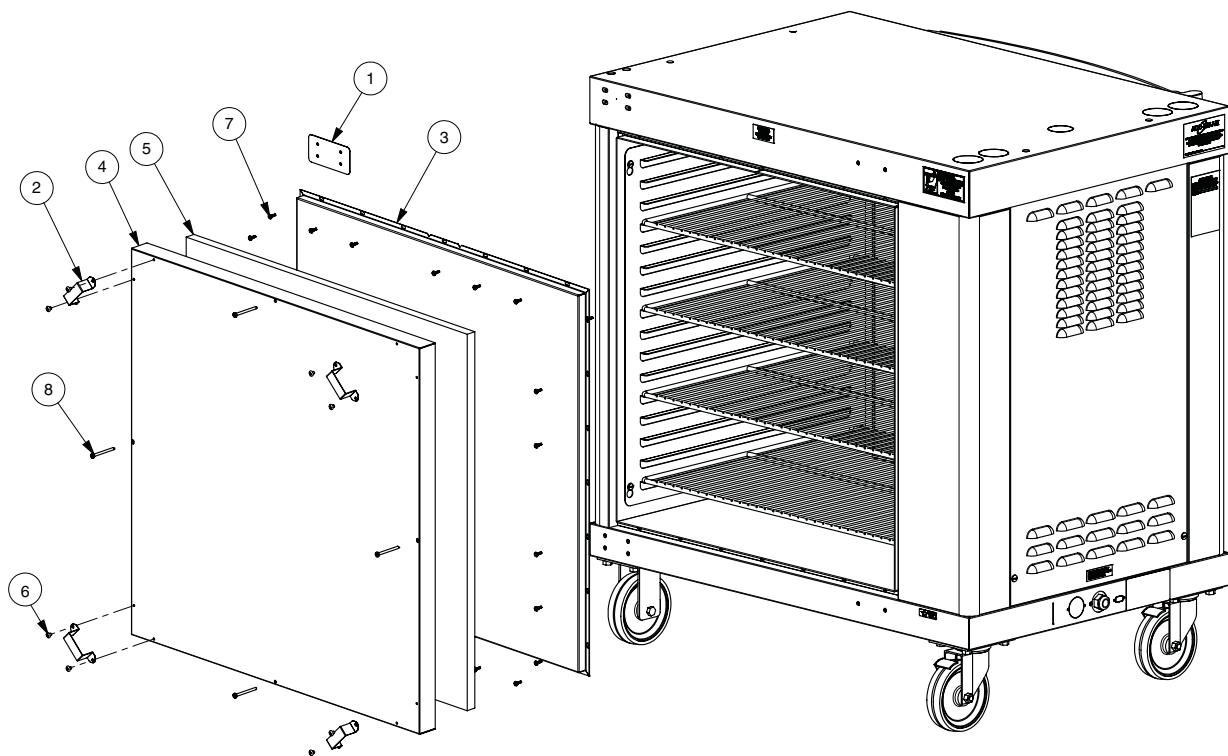

ITEM	DESCRIPTION	PART NO.	QTY
1	COVER, HINGE MOUNTING	1002446	2
2	SPACER, SOLID BACK	1002822	4
3	PANEL, BACK, SOLID, INNER	1006652	1
4	PANEL, BACK, SOLID	1006746	1
5	INSULATION, FIBERGLASS, #3 DENS, 1/2" THICK	IN-2003	2
6	8-32 X 1/4" PHIL SCREW	SC-2459	8
7	SELF TAPPING 8-32 X 1/2	SC-25849	24
8	SCREW, 8/32 X 2 LG.	SC-27843	4
9*	SCREW, 10-32 X 3/4	SC-23151	8

\*NOT SHOWN

Part numbers and drawings are subject to change without notice.

# SERVICE

## ELECTRICAL - MANUAL CONTROL

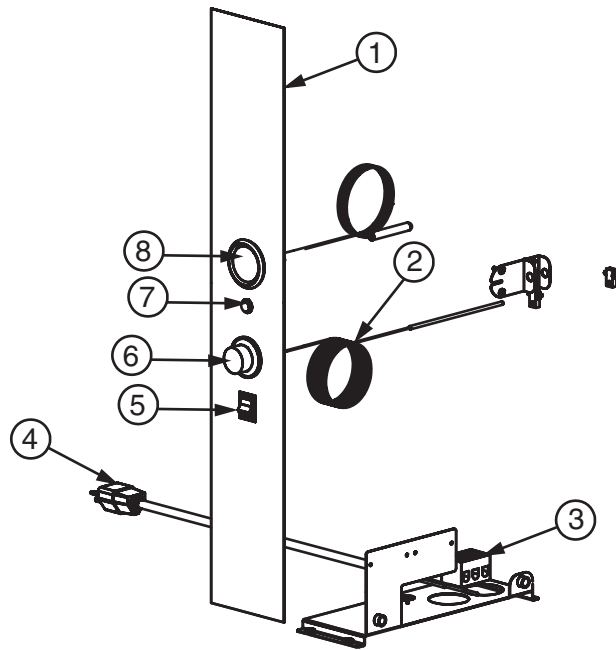

		MODEL >	MANUAL	
ITEM	DESCRIPTION		PART NO.	QTY
1	CONTROL PANEL OVERLAY		PE-26003	1
2	THERMOSTAT, SLOW, 200°F		TT-3057	1
3	T-BLOCK		BK-3019	1
4	CORDSET	120V, 72" (1829mm)	CD-3397	1
		208/240V, 108" (2743mm)	CD-33840	1
		230V, 108" (2743mm)	CD-3922	1
		230V, 108" (2743mm)	CD-36231	1
5	POWER SWITCH, ROCKER		SW-3887	1
6	KNOB, THERMOSTAT	°F	KN-3469	1
		°C	KN-3474	1
7	INDICATOR LIGHT	120V	LI-3027	1
		208/240V	LI-3025	1
		230V	LI-3951	1
8	TEMPERATURE GAUGE		GU-3273	1

Part numbers and drawings are subject to change without notice.

## ELECTRICAL - ELECTRONIC CONTROL

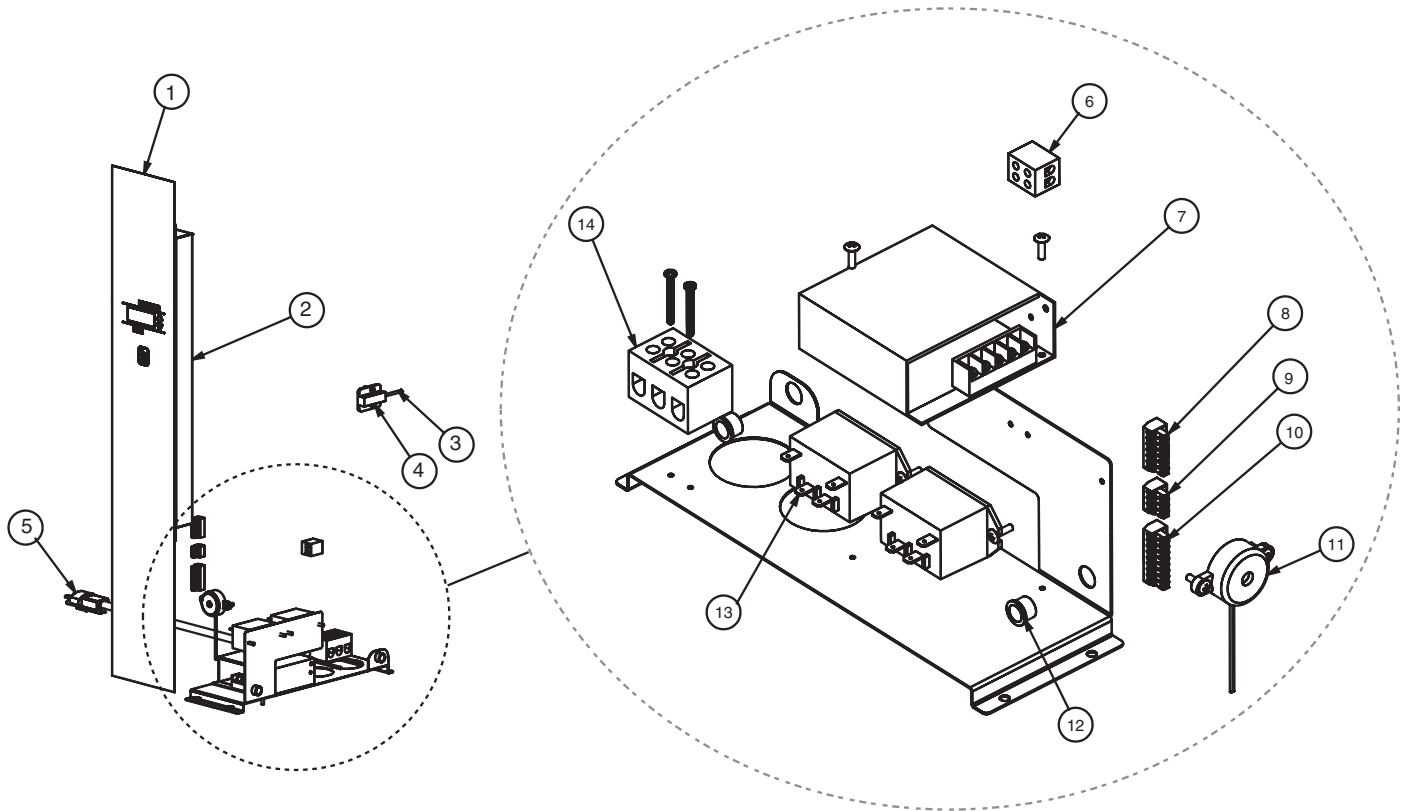

		MODEL >	ELECTRONIC	
ITEM	DESCRIPTION		PART NO.	QTY
1	CONTROL PANEL OVERLAY		PE-25746	1
2	CONTROL, ASSEMBLY		5001771	1
3	SENSOR, TEMPERATURE		SN-33540	1
4	BLOCK, SENSOR		BK-24427	1
5	CORDSET	120V, 72" (1829mm)	CD-3397	1
		208/240V, 108" (2743mm)	CD-33840	1
		230V, 108" (2743mm)	CD-3922	1
		230V, 108" (2743mm)	CD-36231	1
6	BLOCK, TERMINAL, PORCELAIN		BK-33546	1
7	BOARD, POWER SUPPLY, 12V. DC., SWITCH		BK-36144	1
8	CONNECTOR, 7 PIN		CR-33761	1
9	CONNECTOR, 4 PIN		CR-33763	1
10	CONNECTOR, 9 PIN		CR-33718	1
11	BEEPER		BP-3567	1
12	BUSHING		BU-3006	2
13	RELAY		RL-33558	2
14	T-BLOCK		BK-3019	1

Part numbers and drawings are subject to change without notice.



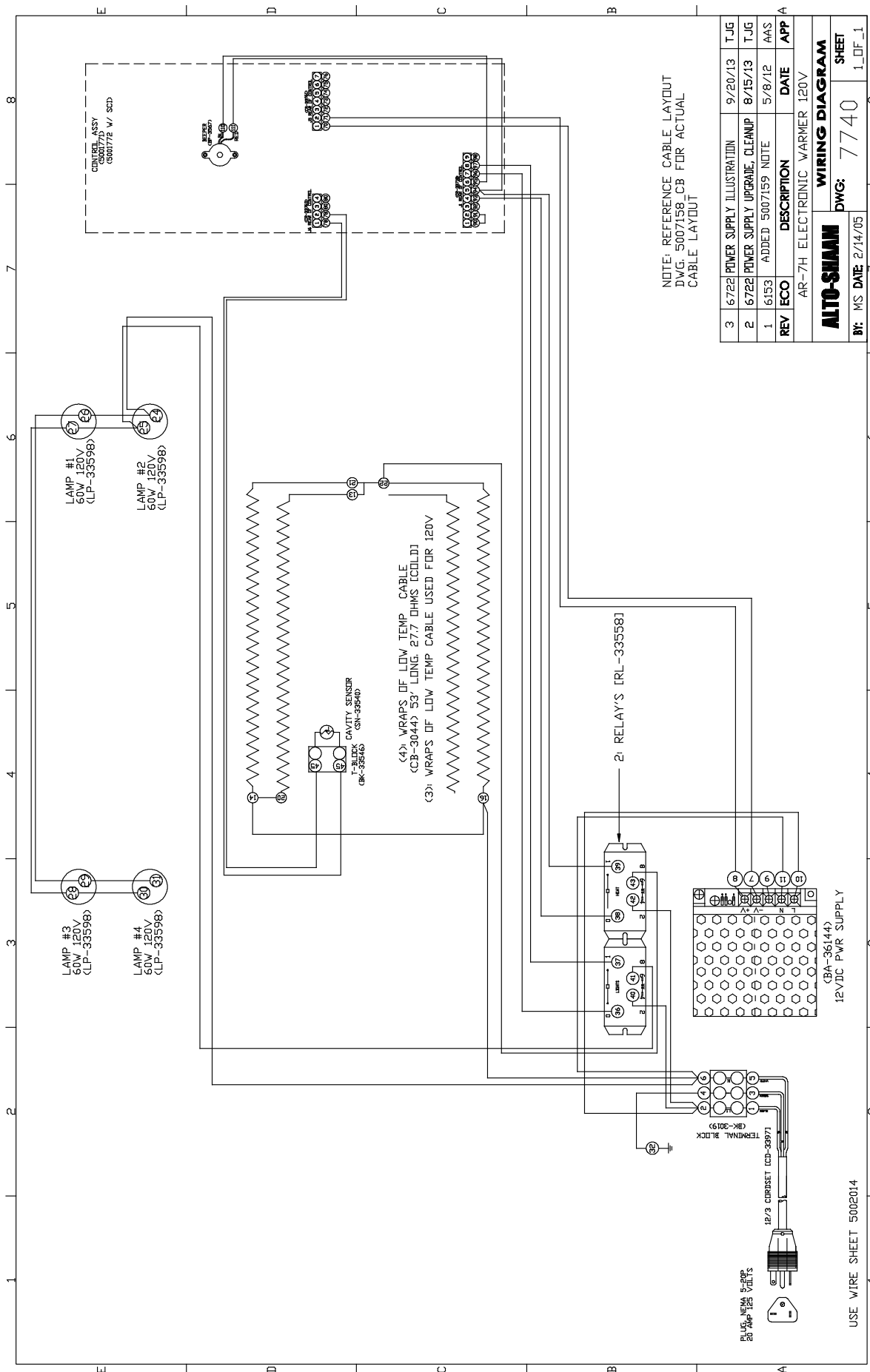

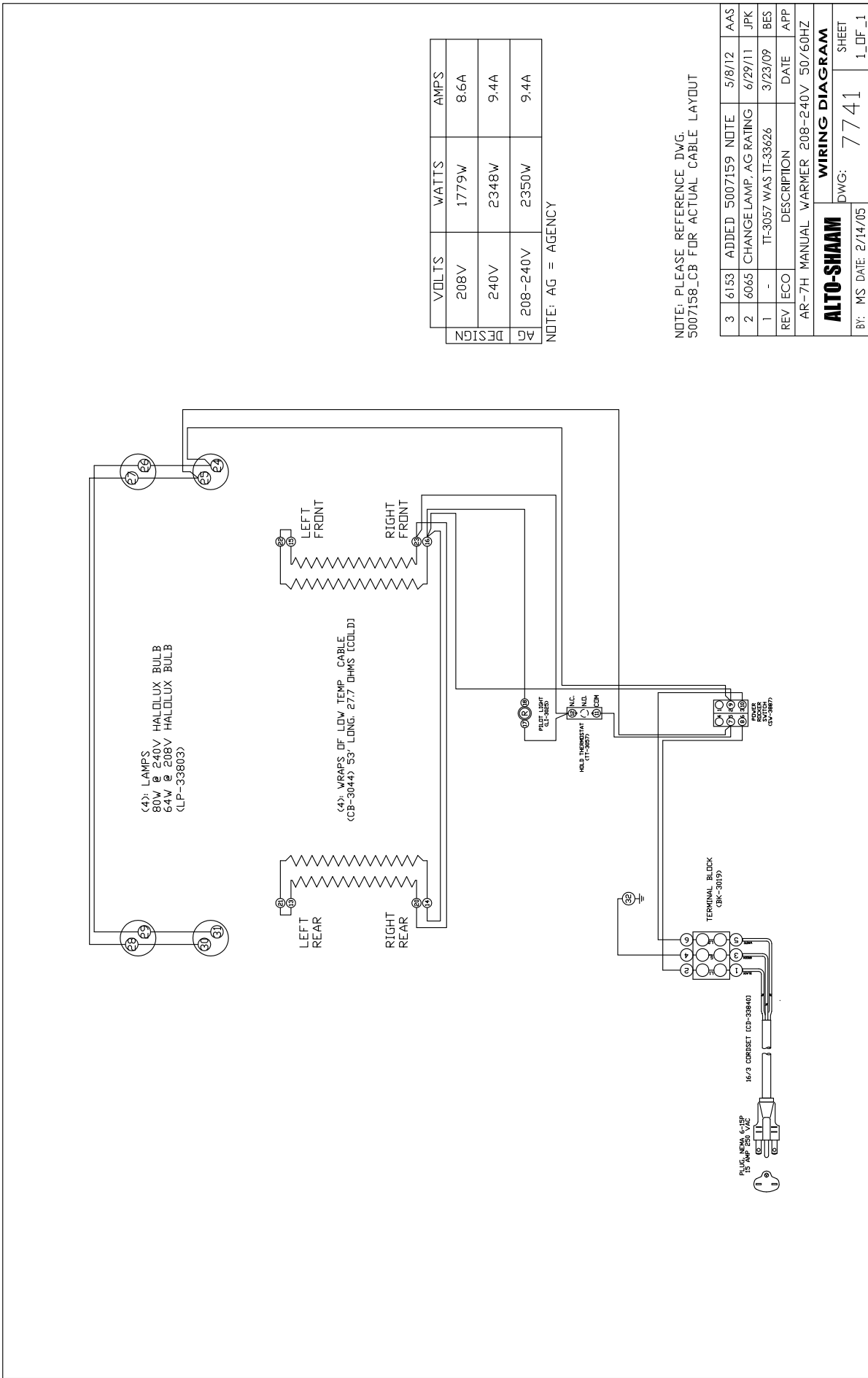

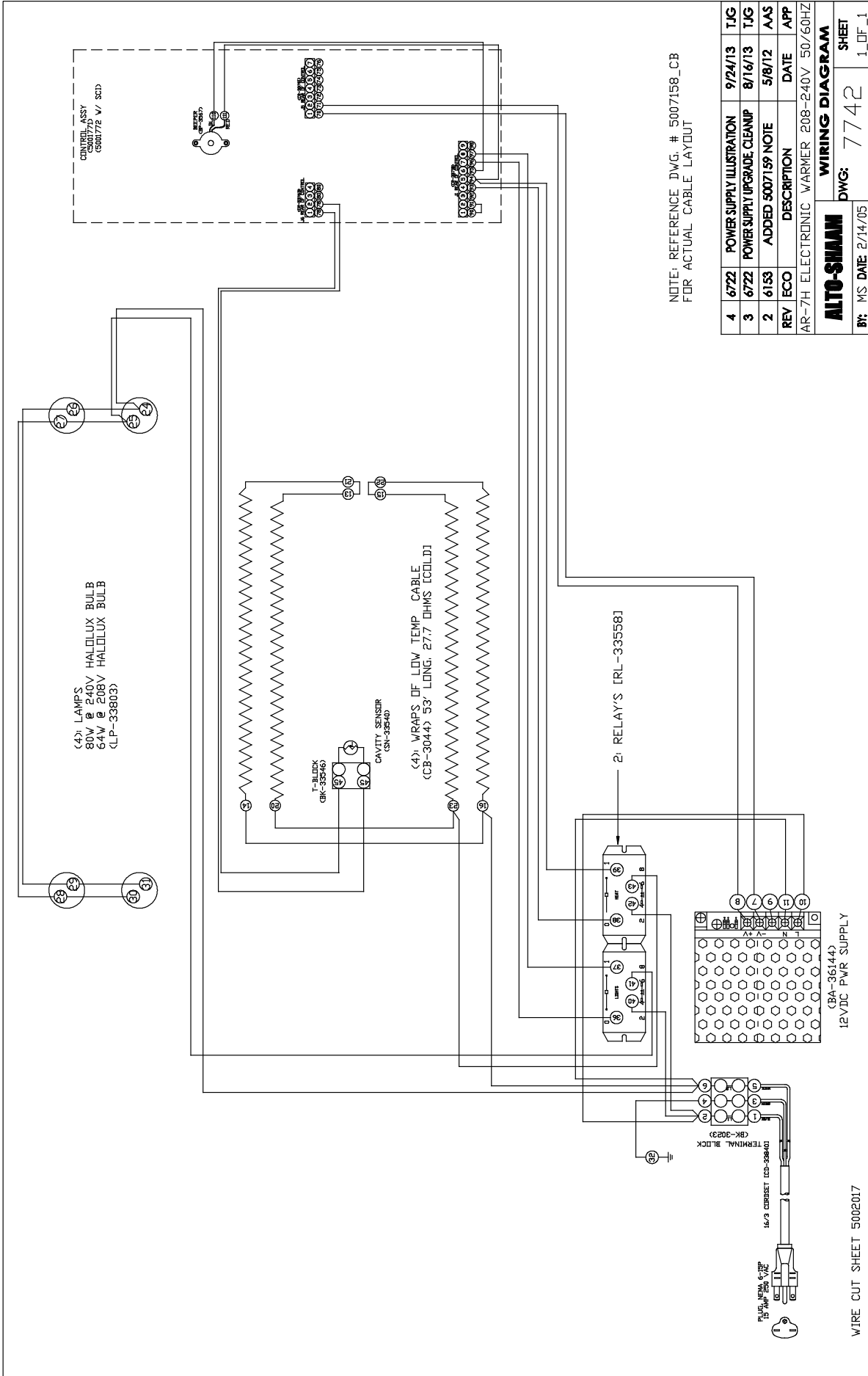





# TRANSPORTATION DAMAGE and CLAIMS



All Alto-Shaam equipment is sold F.O.B. shipping point, and when accepted by the carrier, such shipments become the property of the consignee.

Should damage occur in shipment, it is a matter between the carrier and the consignee. In such cases, the carrier is assumed to be responsible for the safe delivery of the merchandise, unless negligence can be established on the part of the shipper.

1. Make an immediate inspection while the equipment is still in the truck or immediately after it is moved to the receiving area. Do not wait until after the material is moved to a storage area.
2. Do not sign a delivery receipt or a freight bill until you have made a proper count and inspection of all merchandise received.
3. Note all damage to packages directly on the carrier's delivery receipt.
4. Make certain the driver signs this receipt. If he refuses to sign, make a notation of this refusal on the receipt.
5. If the driver refuses to allow inspection, write the following on the delivery receipt:  
*Driver refuses to allow inspection of containers for visible damage.*
6. Telephone the carrier's office immediately upon finding damage, and request an inspection. Mail a written confirmation of the time, date, and the person called.
7. Save any packages and packing material for further inspection by the carrier.
8. Promptly file a written claim with the carrier and attach copies of all supporting paperwork.

We will continue our policy of assisting our customers in collecting claims which have been properly filed and actively pursued. We cannot, however, file any damage claims for you, assume the responsibility of any claims, or accept deductions in payment for such claims.

## LIMITED WARRANTY

Alto-Shaam, Inc. warrants to the original purchaser only that any original part that is found to be defective in material or workmanship will, at Alto-Shaam's option, subject to provisions hereinafter stated, be replaced with a new or rebuilt part.

### The original parts warranty period is as follows:

For the refrigeration compressor on Alto-Shaam Quickchillers™, five (5) years from the date of installation of appliance.

For the heating element on Halo Heat® cooking and holding ovens, as long as the original purchaser owns the oven. This excludes holding only equipment.

For all other original parts, one (1) year from the date of installation of appliance or fifteen (15) months from the shipping date, whichever occurs first.

The labor warranty period is one (1) year from the date of installation or fifteen (15) months from the shipping date, whichever occurs first.

Alto-Shaam will bear normal labor charges performed during standard business hours, excluding overtime, holiday rates or any additional fees.

To be valid, a warranty claim must be asserted during the applicable warranty period. This warranty is not transferable.

### THIS WARRANTY DOES NOT APPLY TO:

1. Calibration.
2. Replacement of light bulbs, door gaskets, and/or the replacement of glass due to damage of any kind.
3. Equipment damage caused by accident, shipping, improper installation or alteration.
4. Equipment used under conditions of abuse, misuse, carelessness or abnormal conditions, including but not limited to, equipment subjected to harsh or inappropriate chemicals, including but not limited to, compounds containing chloride or quaternary salts, poor water quality, or equipment with missing or altered serial numbers.
5. Damage incurred as a direct result of poor water quality, inadequate maintenance of steam generators and/or surfaces affected by water quality. Water quality and required maintenance of steam generating equipment is the responsibility of the owner/operator.
6. Damage caused by use of any cleaning agent other than Alto-Shaam's Combitherm® Cleaner, including but not limited to damage due to chlorine or other harmful chemicals. **Use of Alto-Shaam's Combitherm® Cleaner on Combitherm® ovens is highly recommended.**
7. Any losses or damage resulting from malfunction, including loss of product, food product, revenue, or consequential or incidental damages of any kind.
8. Equipment modified in any manner from original model, substitution of parts other than factory authorized parts, removal of any parts including legs, or addition of any parts.

This warranty is exclusive and is in lieu of all other warranties, express or implied, including the implied warranties of merchantability and fitness for a particular purpose. In no event shall Alto-Shaam be liable for loss of use, loss of revenue or profit, or loss of product, or for any indirect, special, incidental, or consequential damages. No person except an officer of Alto-Shaam, Inc. is authorized to modify this warranty or to incur on behalf of Alto-Shaam any other obligation or liability in connection with Alto-Shaam equipment.



Effective November 1, 2012

RECORD THE MODEL AND SERIAL NUMBER OF THE APPLIANCE FOR EASY REFERENCE.

ALWAYS REFER TO BOTH MODEL AND SERIAL NUMBER IN ANY CONTACT WITH ALTO-SHAAM REGARDING THIS APPLIANCE.

Model: \_\_\_\_\_ Date Installed: \_\_\_\_\_  
Voltage: \_\_\_\_\_ Purchased From: \_\_\_\_\_  
Serial Number: \_\_\_\_\_

W164 N9221 Water Street • P.O. Box 450 • Menomonee Falls, Wisconsin 53052-0450 • U.S.A.

PHONE: 262.251.3800 • 800.558-8744 USA/CANADA FAX: 262.251.7067 • 800.329.8744 U.S.A. ONLY

www.alto-shaam.com

PRINTED IN U.S.A.